

New, sustainable
corrosion protection of
aircraft grade aluminium

Linnea Selegård, Peter Eriksson, Zhangjun Hu,
Kajsa Uvdal

2019-10-09

Intro

Anodizing

Sealing

Result

Summary

Future

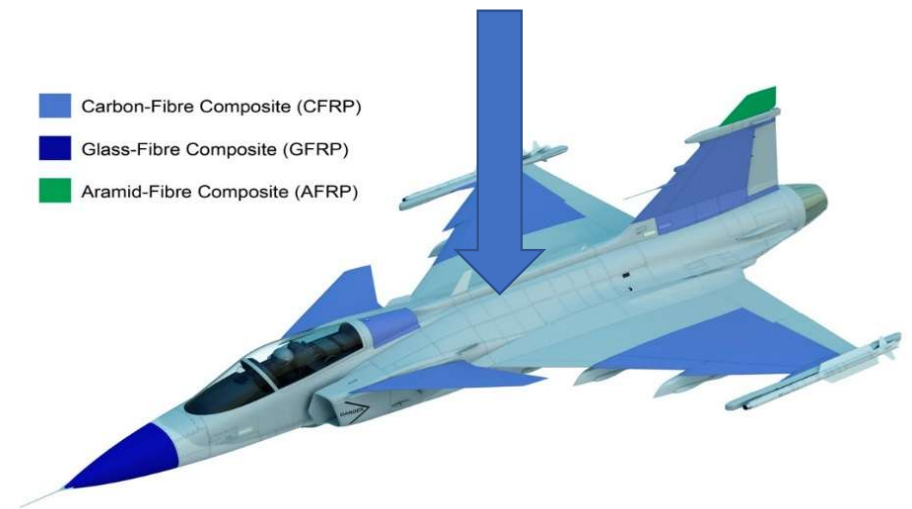

- Carbon-Fibre Composite (CFRP)
- Glass-Fibre Composite (GFRP)
- Aramid-Fibre Composite (AFRP)

- 80% Aluminum
- Cu-containing alloy
- Susceptible to corrosion
- Surface treatment



Intro

Anodizing

Sealing

Result

Summary

Future

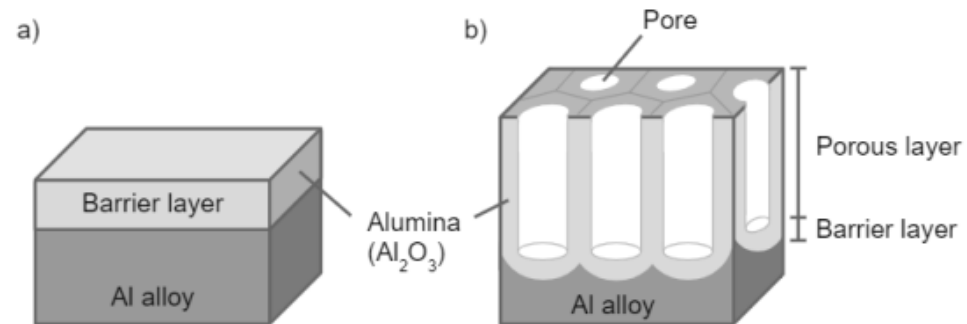
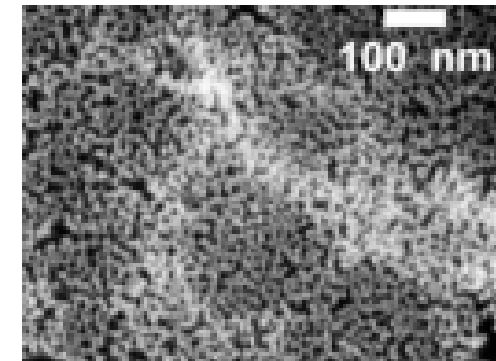
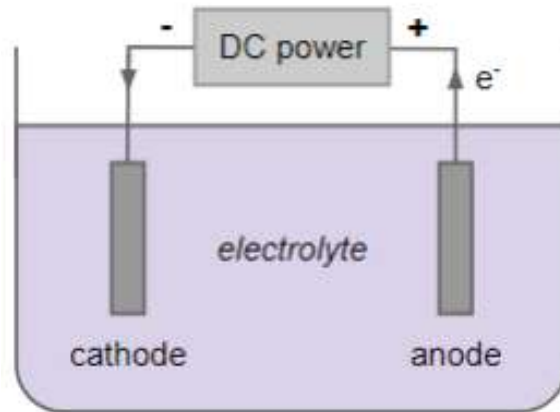

Intro

Anodizing

Sealing

Result

Summary

Future

Tartaric-Sulphuric acid

anodizing

Chromic acid

anodizing



Intro

Anodizing

Sealing

Result

Summary

Future

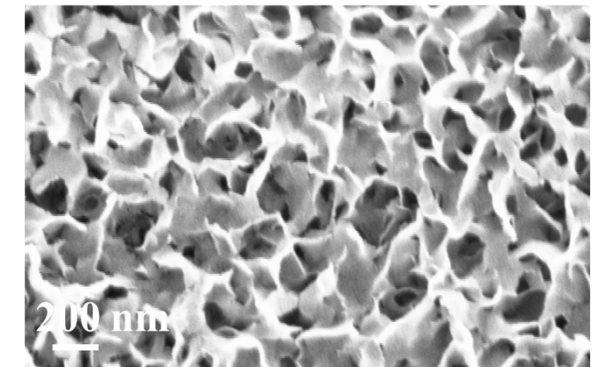
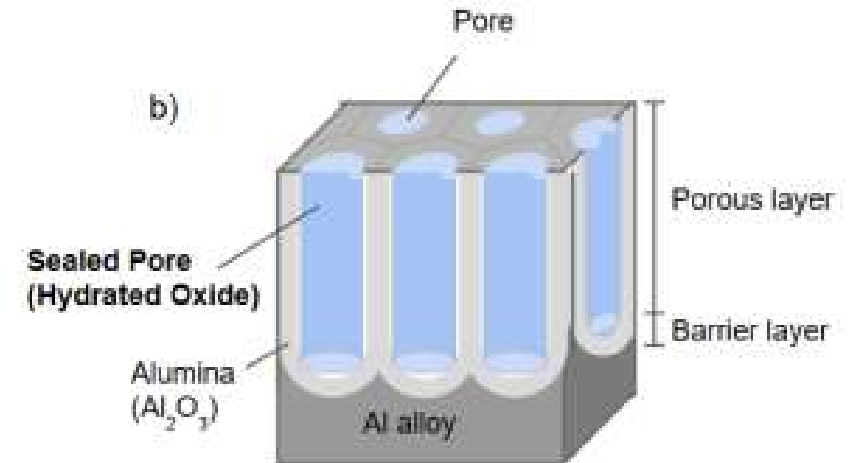
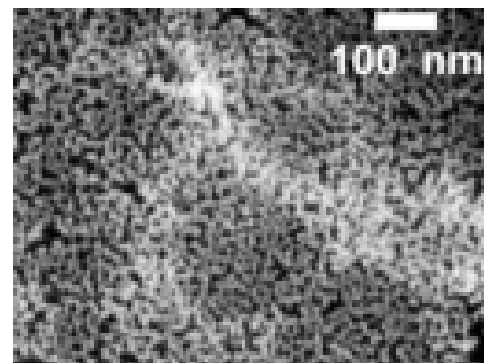
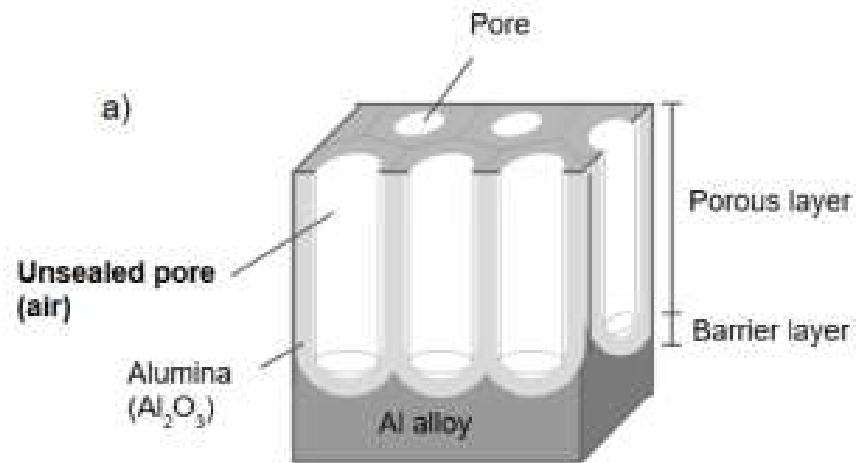

- Hot-water treatment, with or without sodium chromate
- Closes pores
- Improved corrosion protection
- No obvious replacement for chromium

Intro

Anodizing

Sealing

Result

Summary

Future

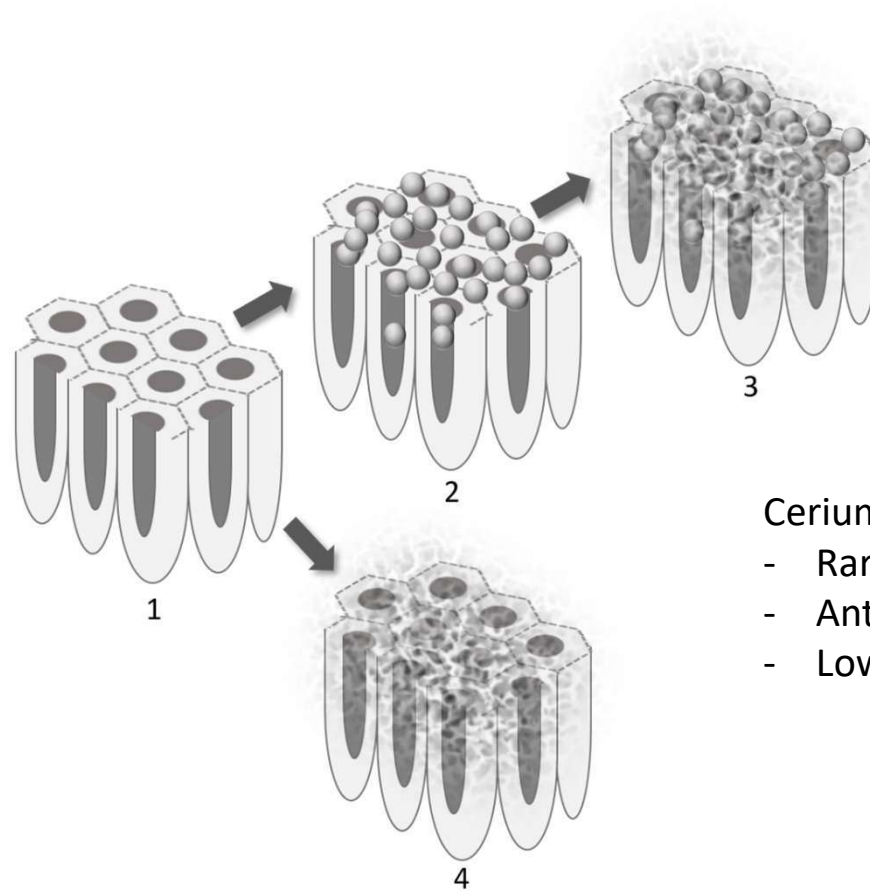

Cerium:

- Rare-earth material (however not rare)
- Anti-oxidant behaviour
- Low toxicity

Intro

Anodizing

Sealing

Results

Summary

Future

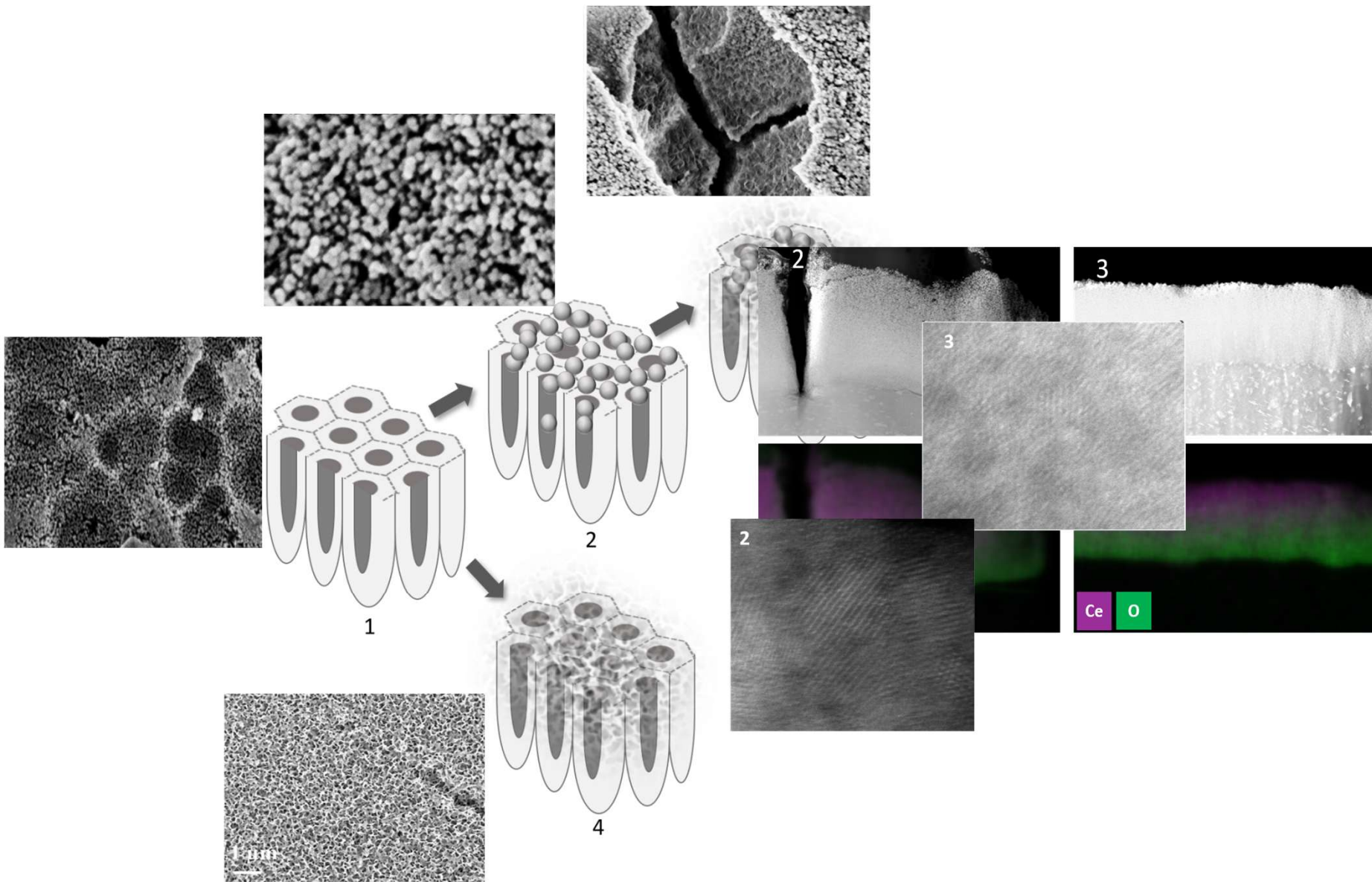

Intro

Anodizing

Sealing

Results

Summary

Future

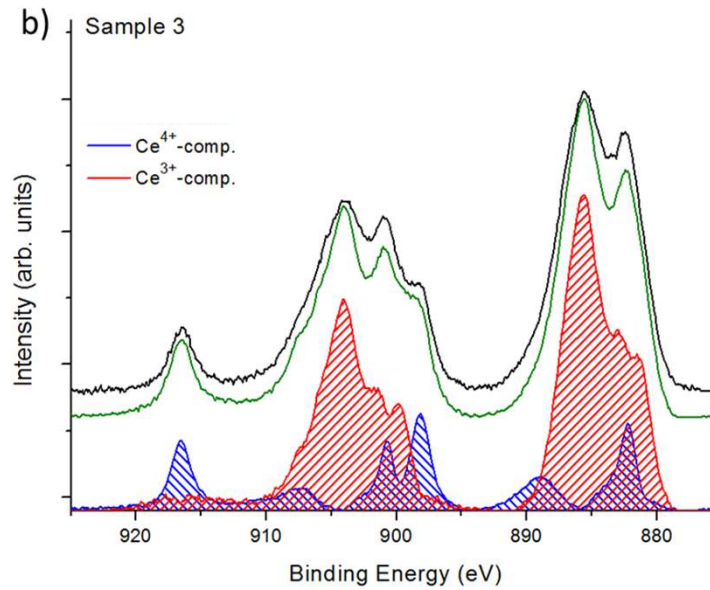
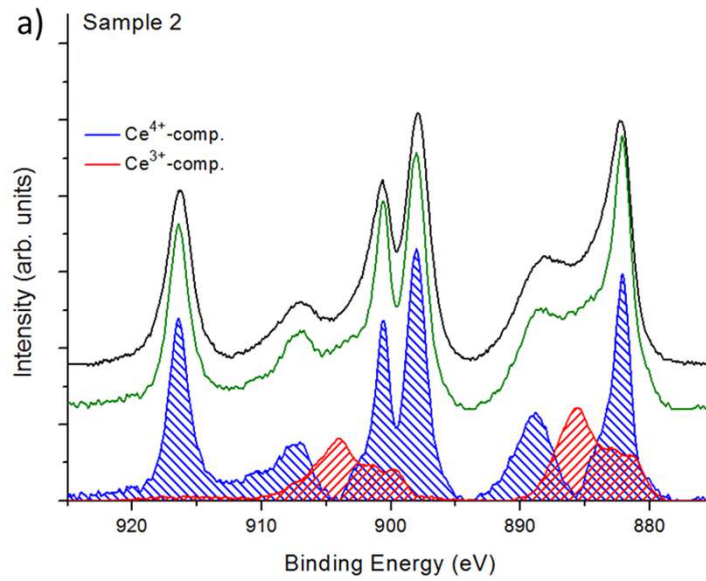
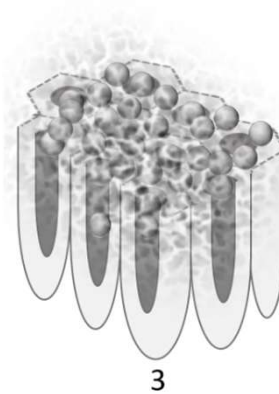
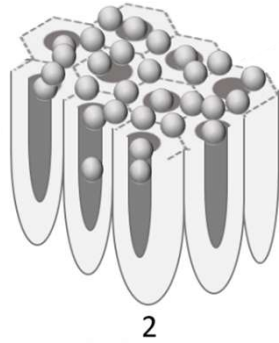

Intro

Anodizing

Sealing

Results

Summary

Future

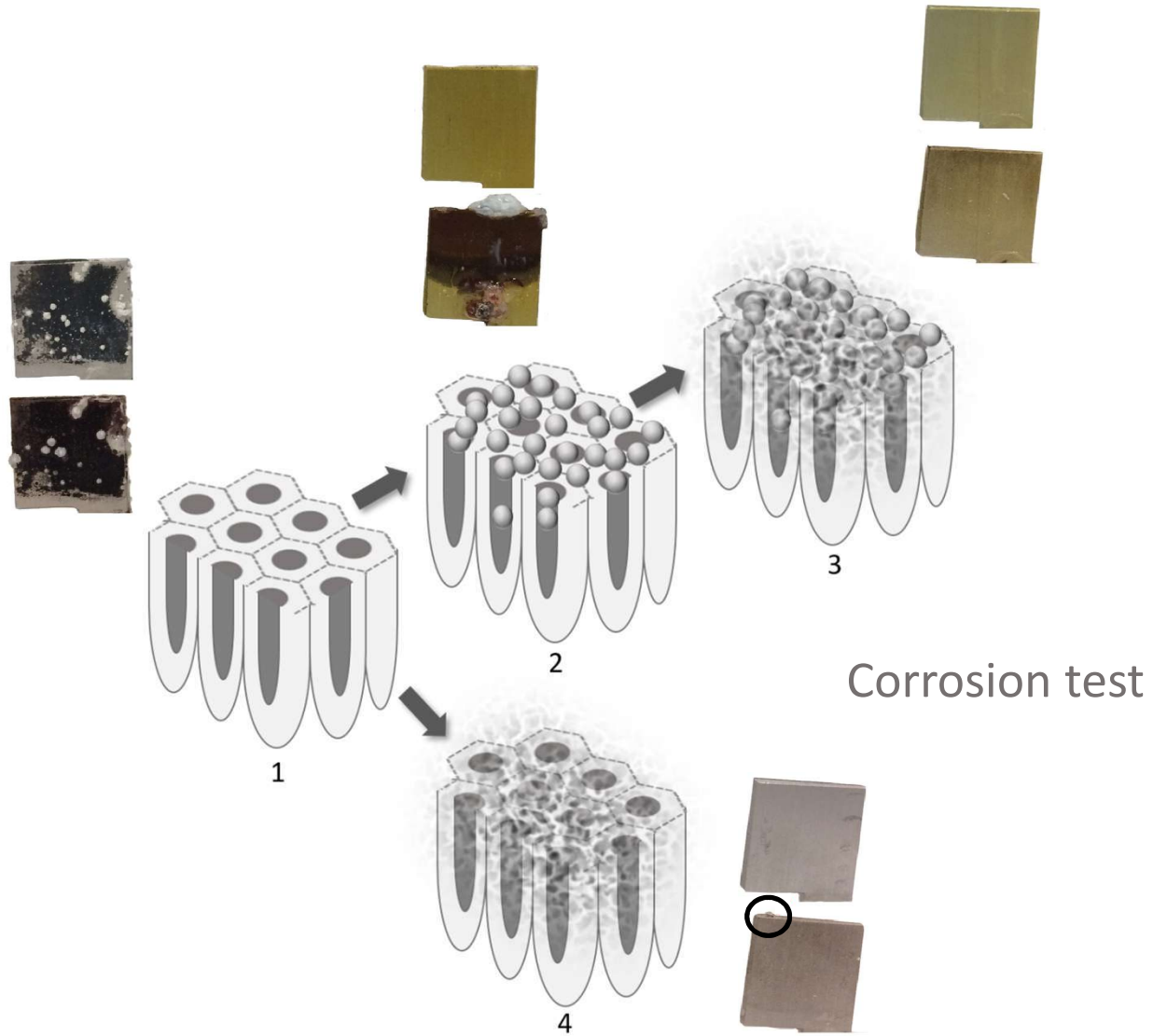

Intro

Anodizing

Sealing

Results

Summary

Future

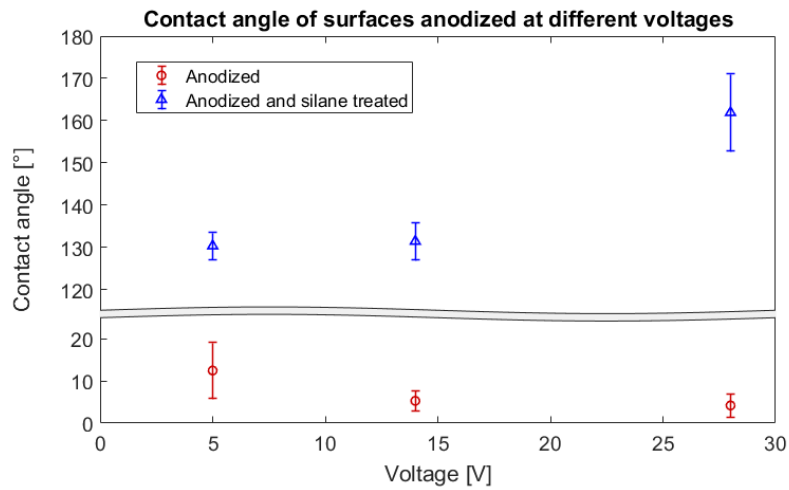
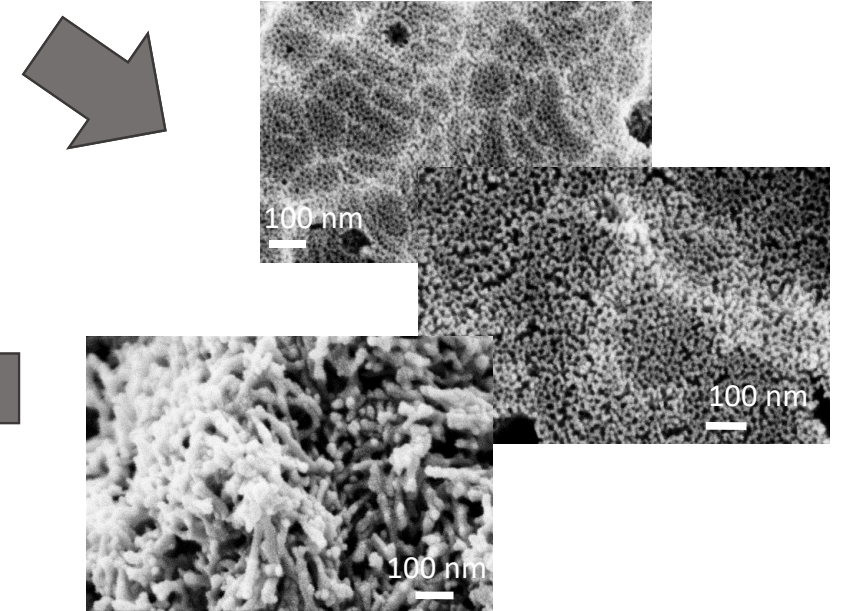

Intro

Anodizing

Sealing

Result

Summary

Future

- **Successfull sealing**
- **Anti-oxidant material -- > corrosion resistant surfaces**
- **Super hydrophobic surfaces**

Future

- Multifunctional coating for aeronautical applications
- Reduced ice-adhesion, improved corrosion resistance and self-cleaning



Acknowledgements

VINNOVA
Materialbaserad konkurrenskraft



**RI
SE**

li.U LINKÖPING
UNIVERSITY



SAAB



Questions