

A NON-DESTRUCTIVE METHOD FOR EVALUATING CARBON FIBER COMPOSITES USING A COST- EFFECTIVE SUB-TERAHERTZ SOURCE AND DETECTOR

Professor Euclides Chuma

Outline

- **The Terahertz**
- **Resonant Tunneling Diodes**
- **Measurement Setup**
- **Results**
- **Conclusions**

The Terahertz

The terahertz region within the electromagnetic spectrum has historically been referred to as the "terahertz gap" due to the technological challenges associated with generating, detecting, and manipulating THz waves.

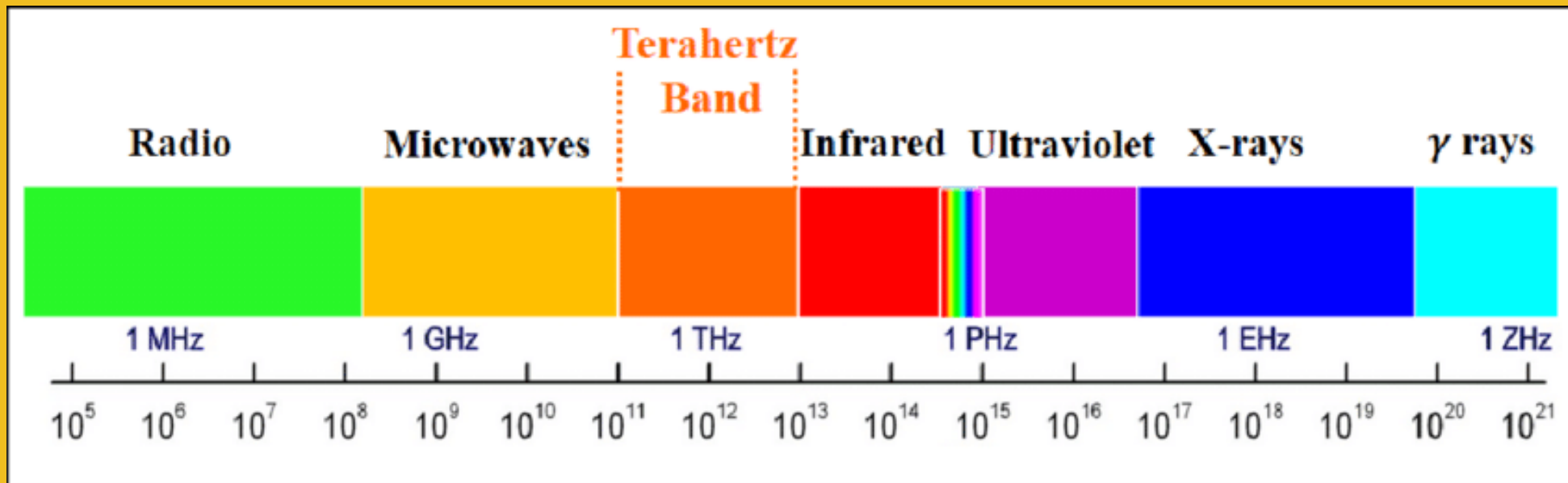

The Terahertz

Why is terahertz important?

- Terahertz can penetrate dielectric materials: clothes, wood, plastic, etc.
- Polymer materials may have unique absorption characteristics in terahertz (Spectrum fingerprints).
- On terahertz is possible to obtain high data transfer rates (over 100 Gbps).

The Terahertz

Terahertz radiation is currently employed in safety and security applications due to its exceptional capacity for non-destructive material detection without posing health risks.

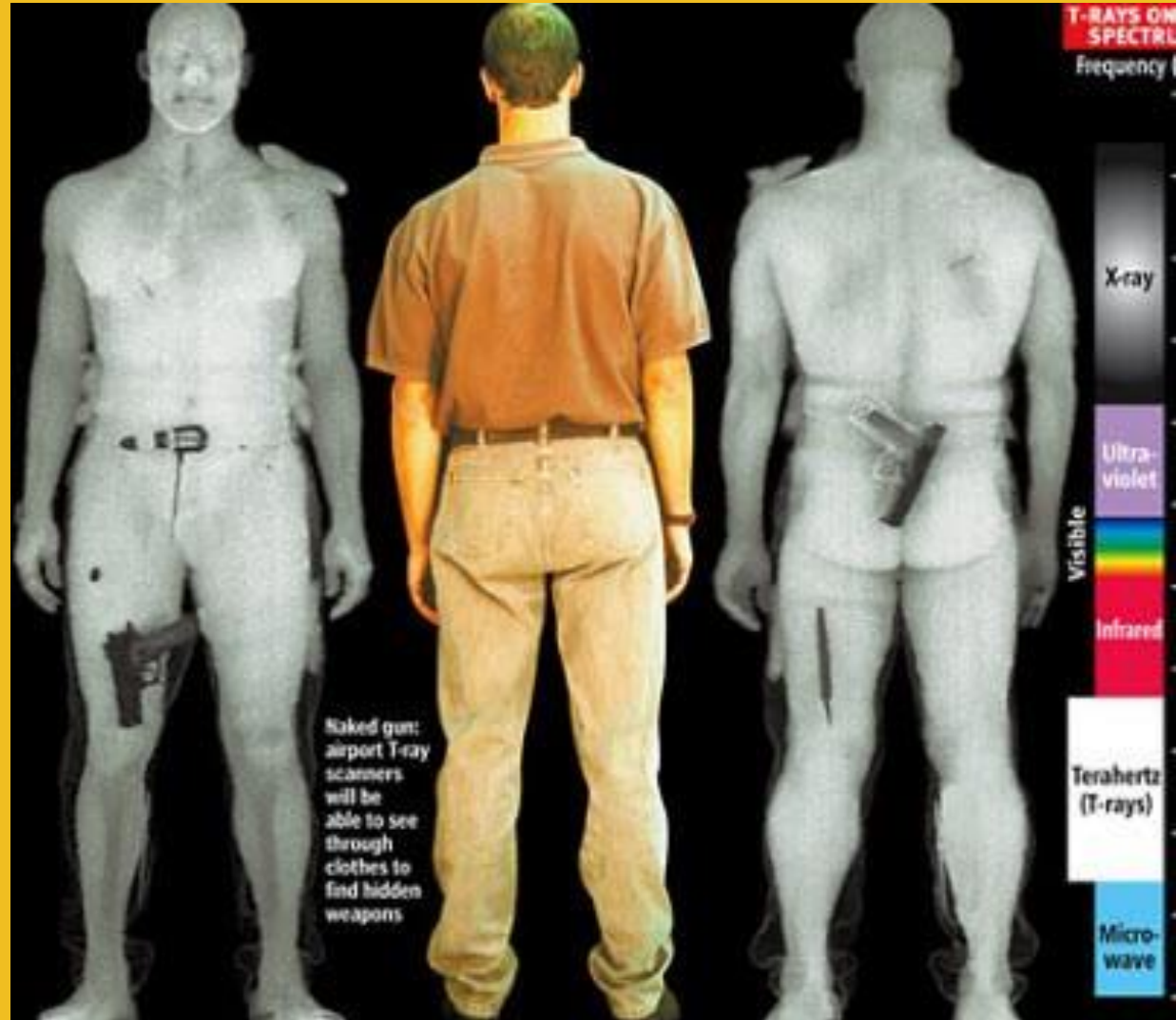

The Terahertz

The fingerprint spectrum of terahertz radiation makes it possible to identify substances and analysis of physical properties.



Resonant Tunneling Diodes

Until recently, working with technologies in the terahertz range required expensive and complex equipment and components.

However, THz diode semiconductors have gained popularity due to their cost-effective ability to generate and detect THz waves.

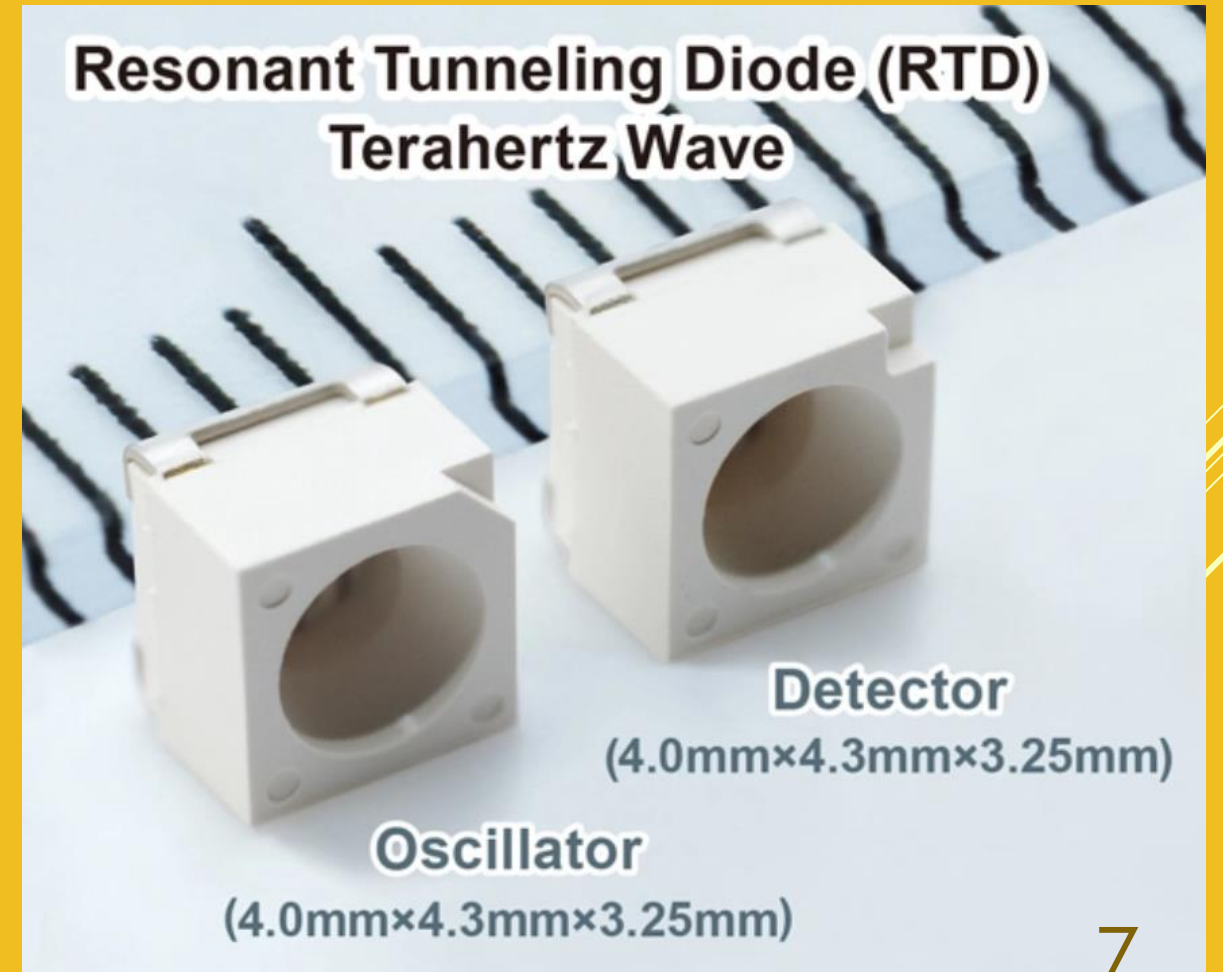

Resonant Tunneling Diodes

Resonant Tunneling Diodes can offer terahertz technology at a lower price.

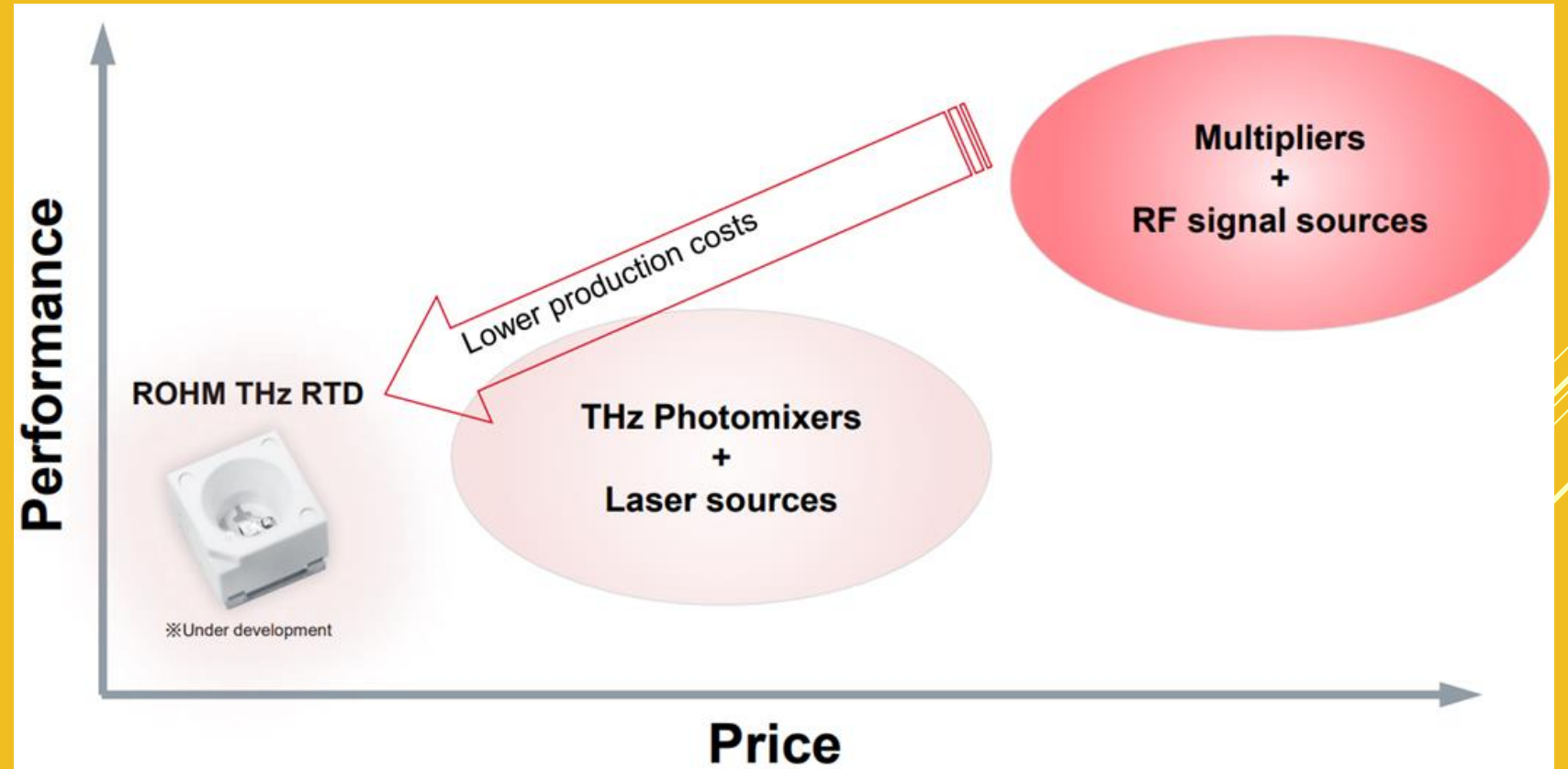

Resonant Tunneling Diodes

Comparative table between Resonant Tunneling Diodes and other terahertz technologies

	THz- Multipliers	Photo Mixers	RTD
Output power	🎯	○	○
Power consumption	✗	✗	🎯
Size	✗	✗	🎯
Cost	✗	✗	🎯
Mass Production	✗	✗	🎯

Resonant Tunneling Diodes

Resonant Tunneling Diodes are constructed with a dual-barrier structure, typically consisting of two semiconductor layers separated by a thin barrier layer.

This configuration exhibits a distinctive current-voltage (I-V) curve, characterized by a highly nonlinear pattern. It typically includes a region of negative differential resistance (NDR).

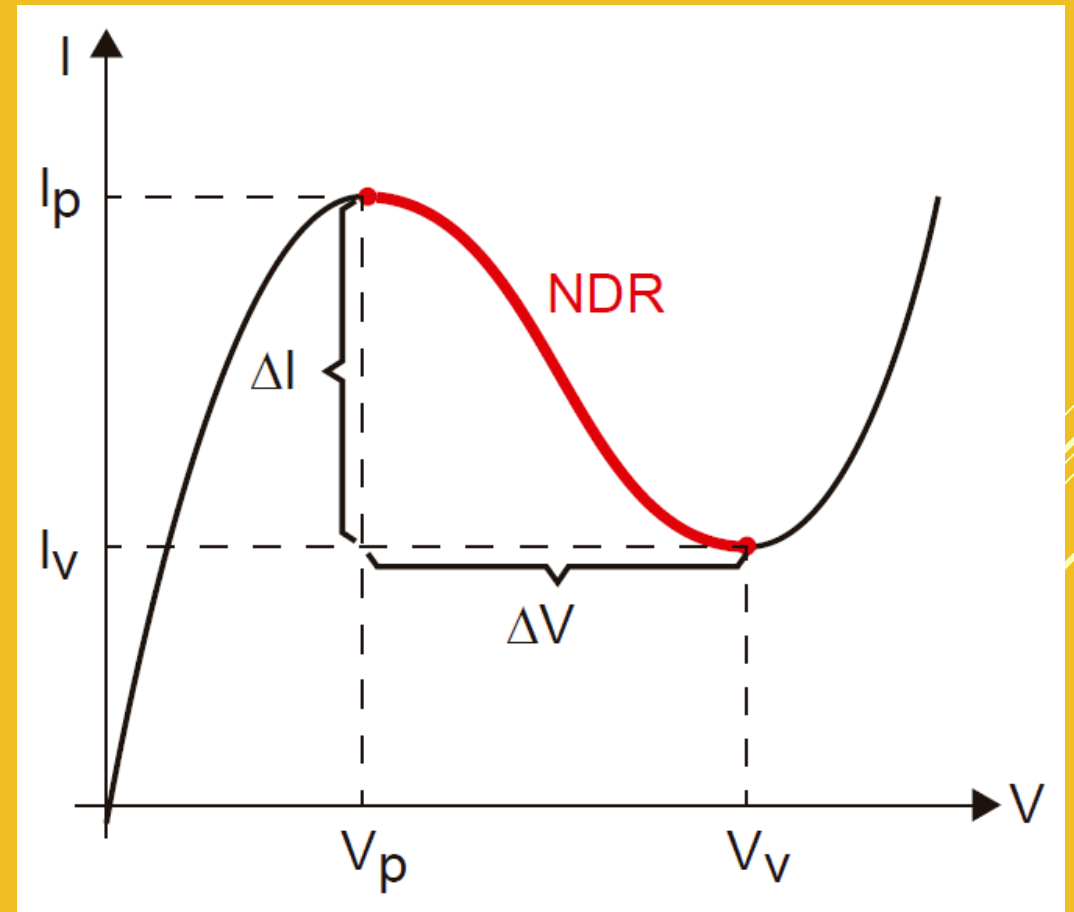

Resonant Tunneling Diodes

Resonant Tunneling Diodes can function as extremely sensitive THz detectors due to their minimal capacitance and pronounced nonlinearity when operating under zero bias conditions and using an integrated antenna structure to achieve a wideband operation.

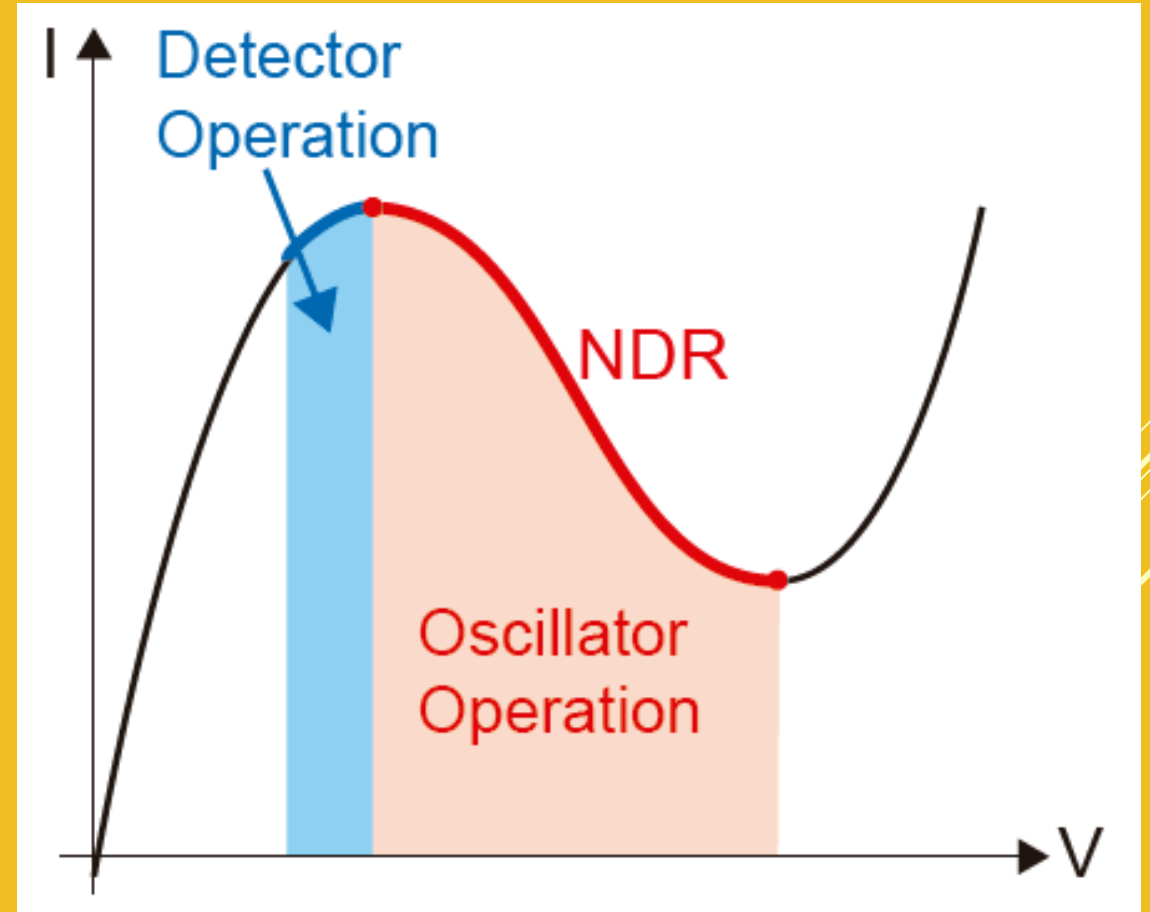

Resonant Tunneling Diodes

The THz source and THz detector devices used in the work were fabricated and provided by ROHM Co., Ltd.

The THz source operates at a frequency of 288 GHz with an output power of 8 μ W.



Resonant Tunneling Diodes

The RTDs used in this work have a plastic leaded chip carrier package similar to packages used in SMD LEDs:

- Package size: 4 x 4 mm
- Easily integrated into handheld / wearable / compact devices

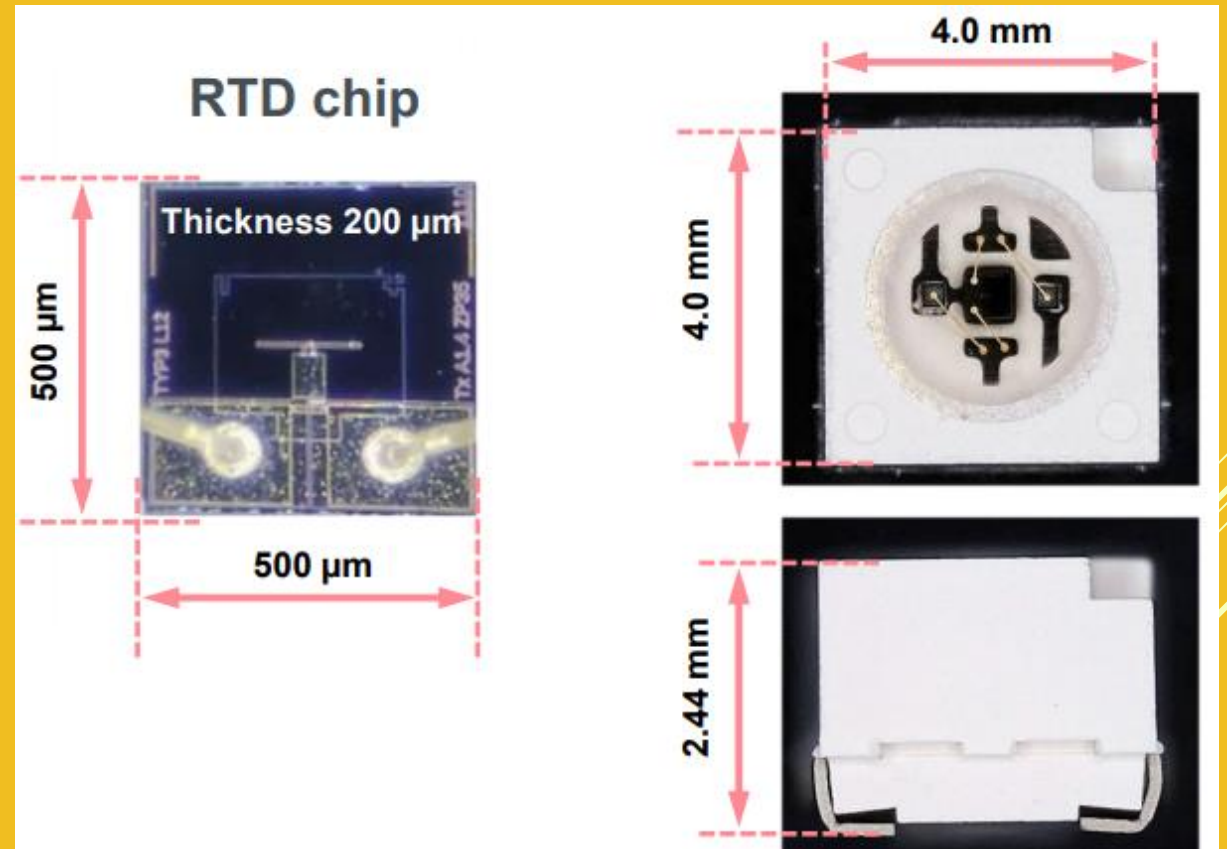

Resonant Tunneling Diodes

RTDs can be used to determine:

- Material thickness
- Material type
- Impurities hidden in the material

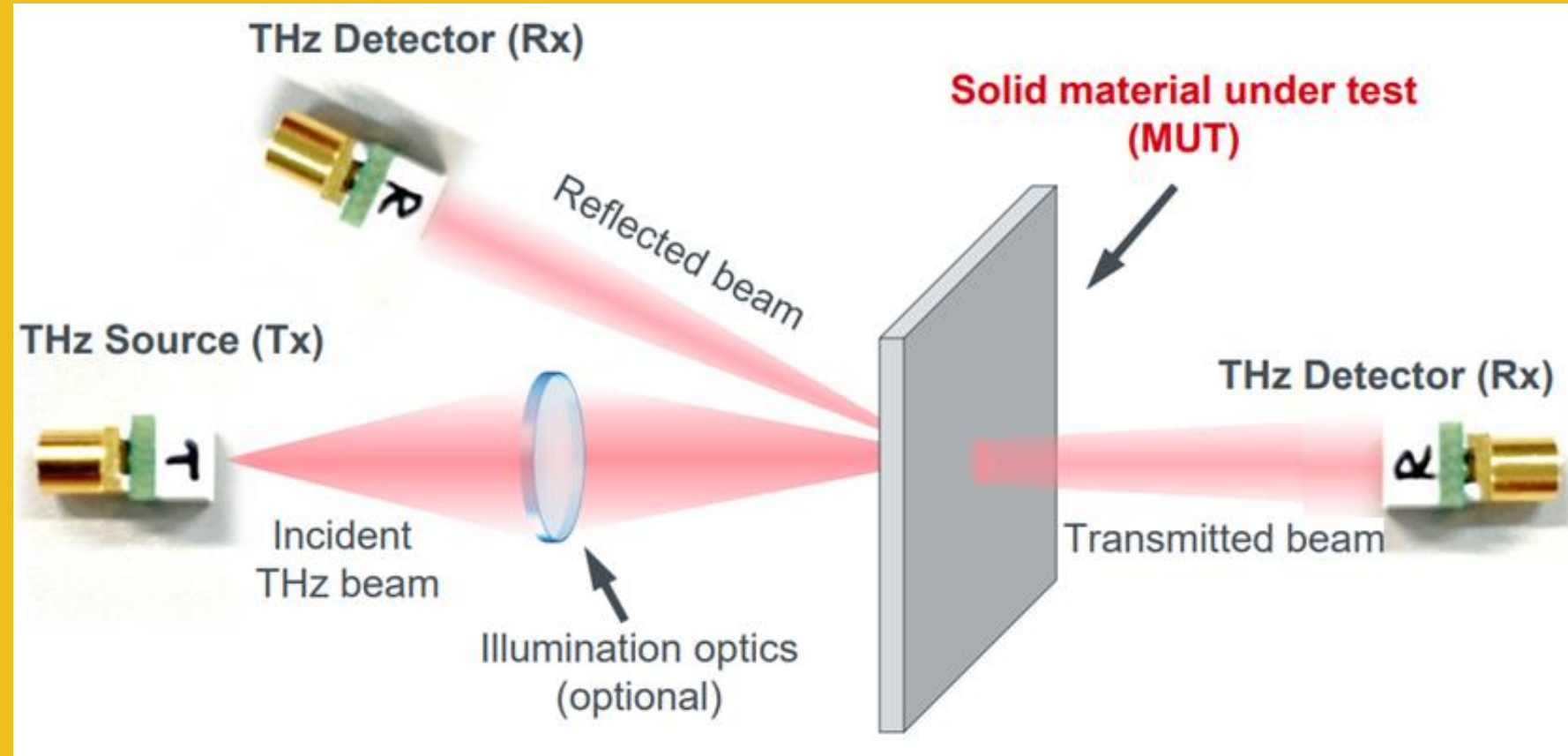

Measurement Setup

The measurement setup used in the work consists of a CFRP sheet fixed to an XY-stage that scans the area below the terahertz source and sensor. The FFT is generated from the terahertz sensor signal, and the peak power is acquired for each XY scan position.

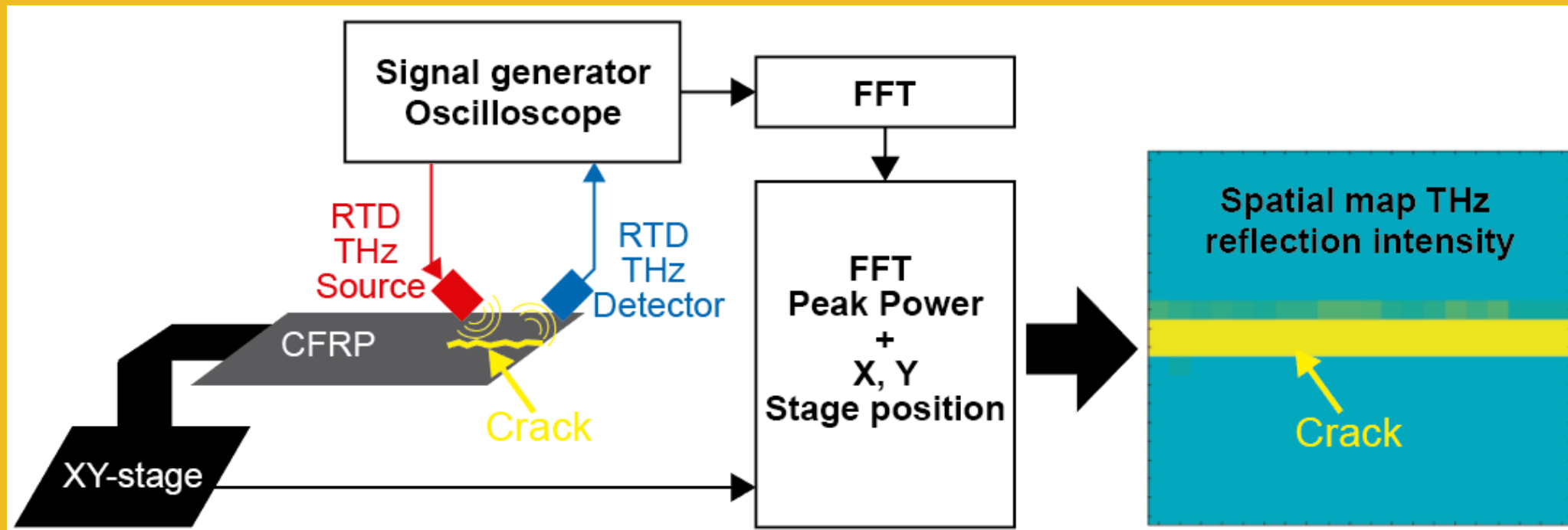

Measurement Setup

The measurement setup was based on a reflection THz raster imaging system, utilizing a THz source and detector positioned at a fixed angle of 45 degrees between them, with a 3 mm distance between the THz source and detector and the CFRP sheet.

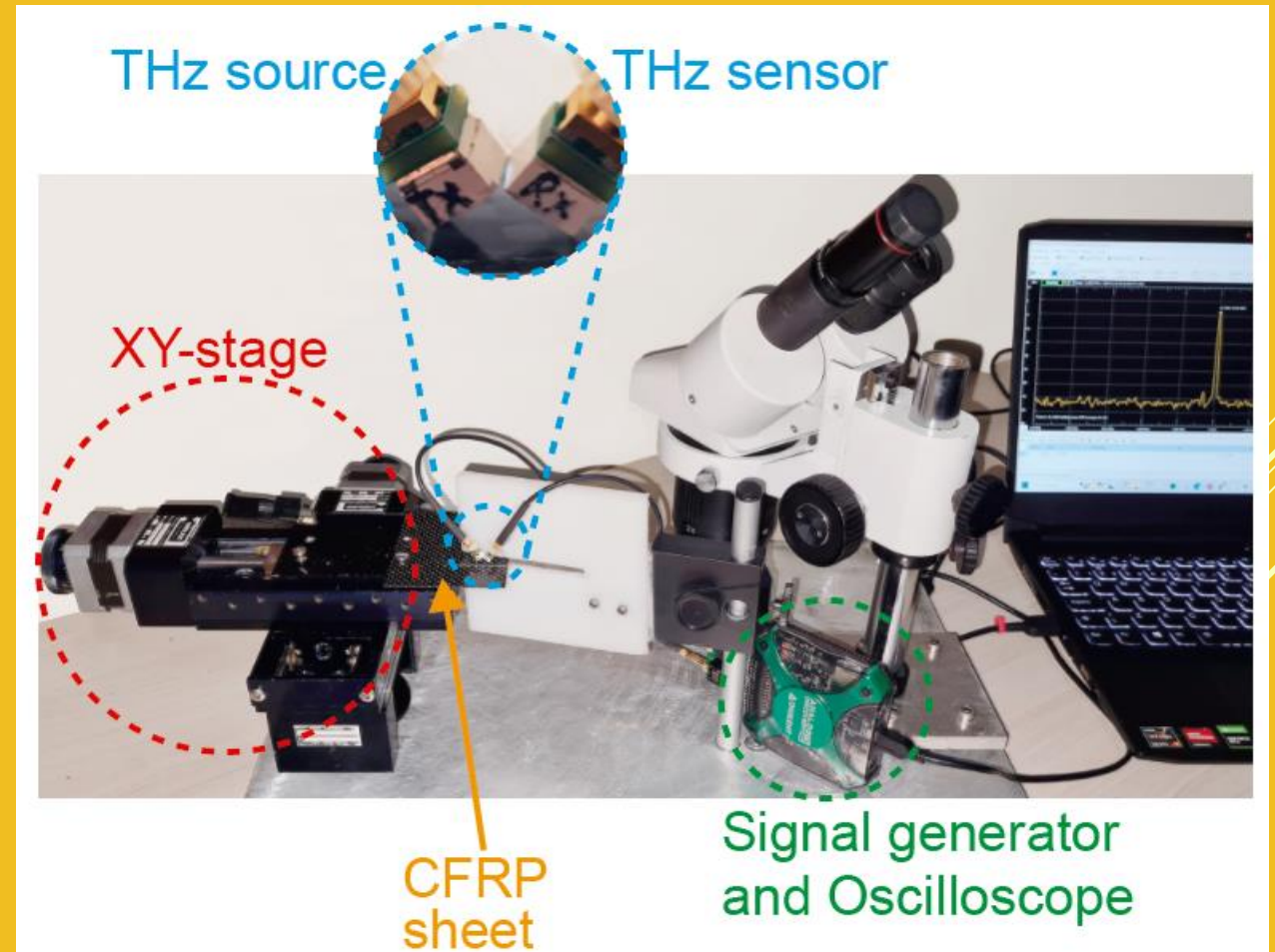

Measurement Setup

The CFRP sheet, featuring scratches and cracks, was securely positioned on the XY-stage, which had been programmed to scan an area measuring 4 mm x 4 mm in increments of 0.2 mm.



Measurement Setup

The CFRP sheet used for the measurements is a standard 3K CFRP sheet with scratches and cracks artificially created.

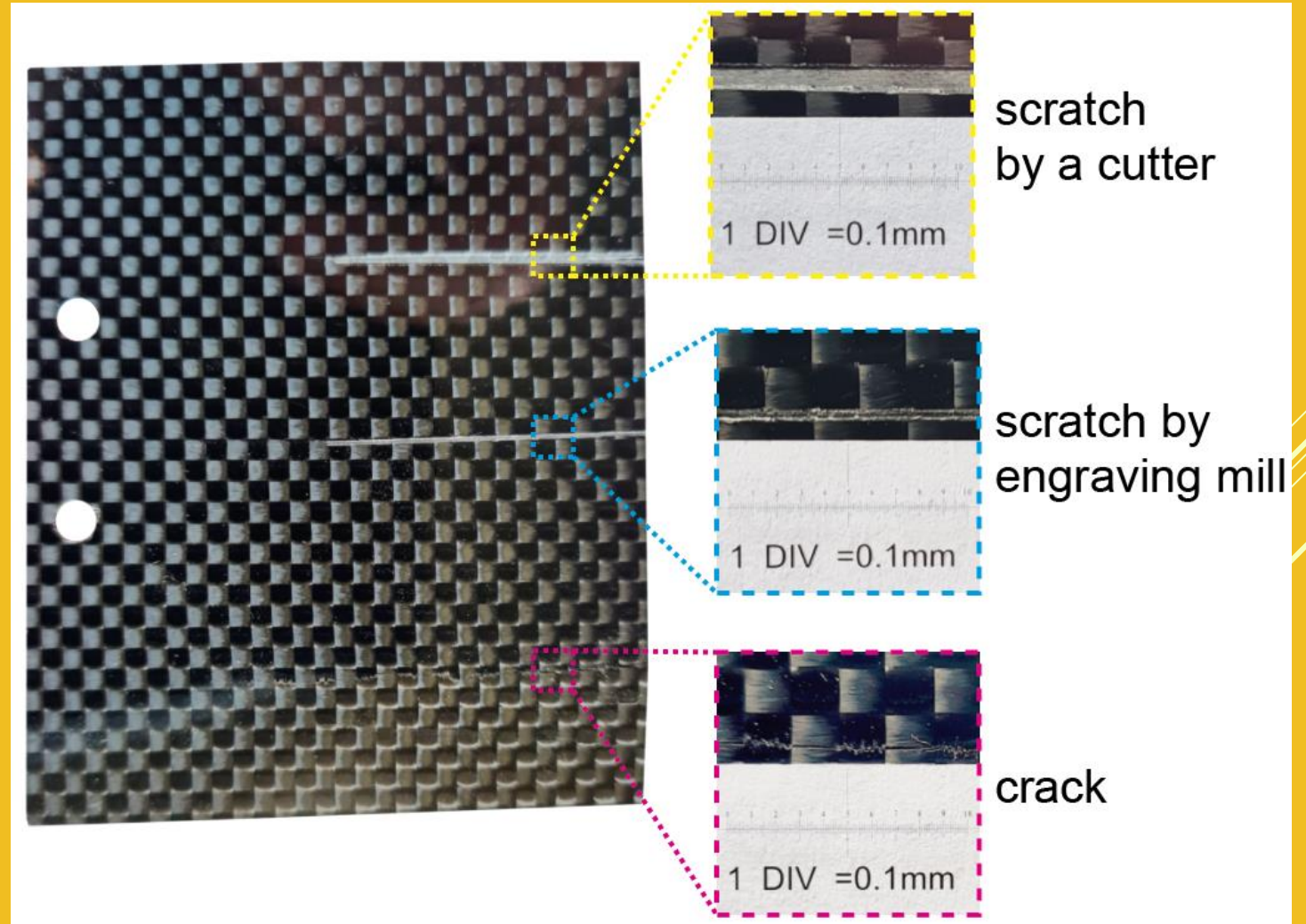

Measurement Setup

The THz source and detector signals are generated and acquired into a single equipment (Digilent Analog Discovery 2), incorporating a signal generator and oscilloscope, and are connected to the computer via a USB port for communication.

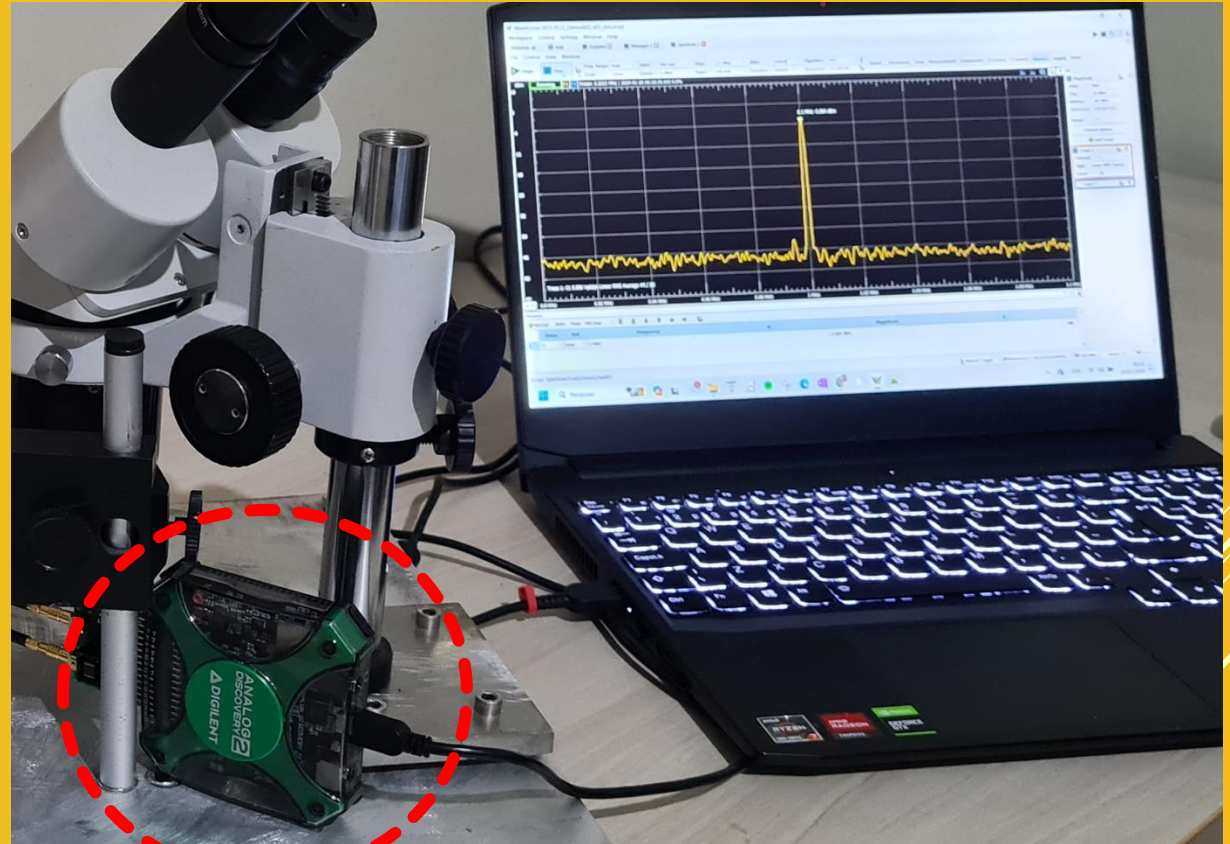

Measurement Setup

The Figure shows a block diagram of the THz measurement setup used in the work.

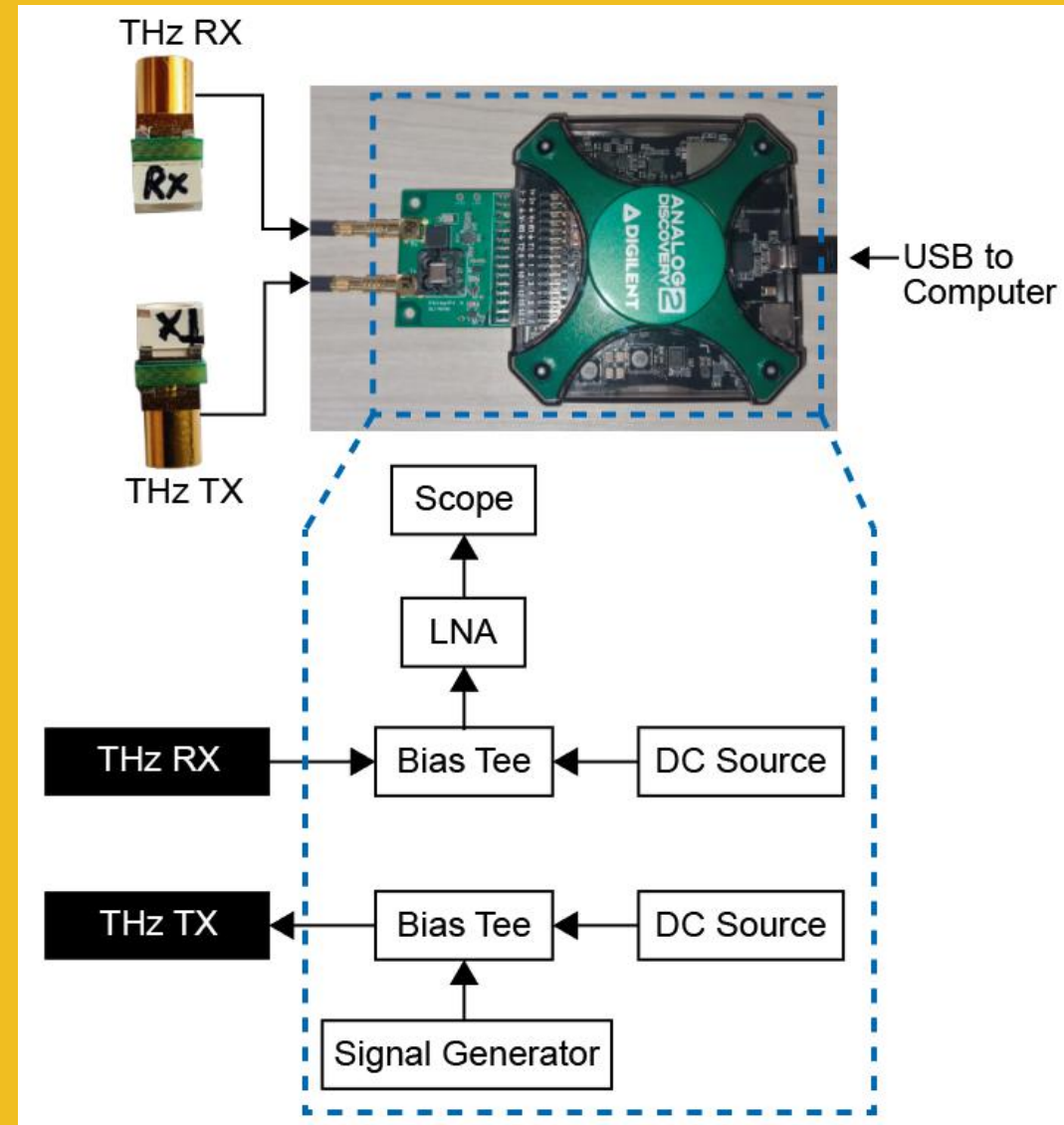

Results

For each XY position of the stage, the FFT peak power was recorded, generating a matrix of 20 x 20 peak powers for each scratch and crack.

These matrices were imported into Matlab software, which was employed to create images with scaled colors representing the spatial map of THz reflection intensity.

Results

It is possible to see that the THz reflection intensity in the scratch produced by a cutter shows variation in its width, while the scratch created by an engraving mill appears well-defined.

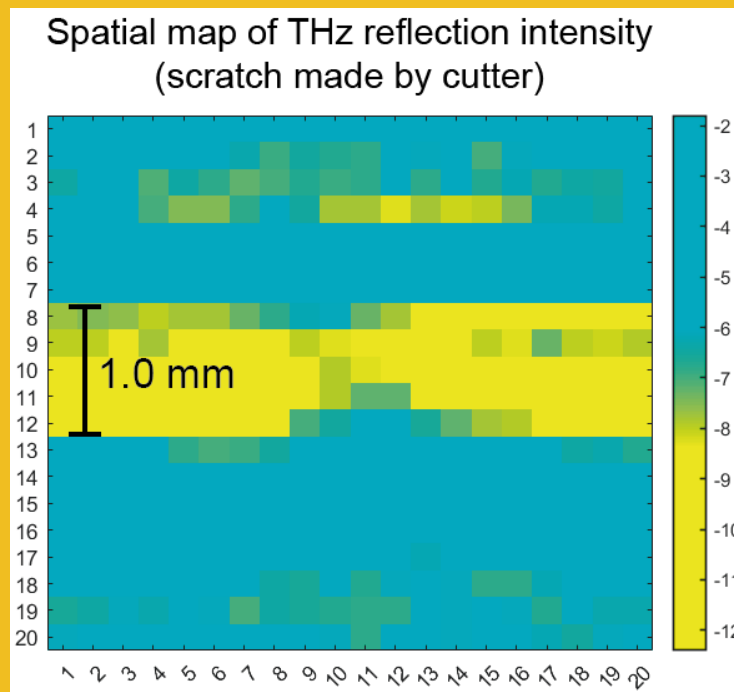

X

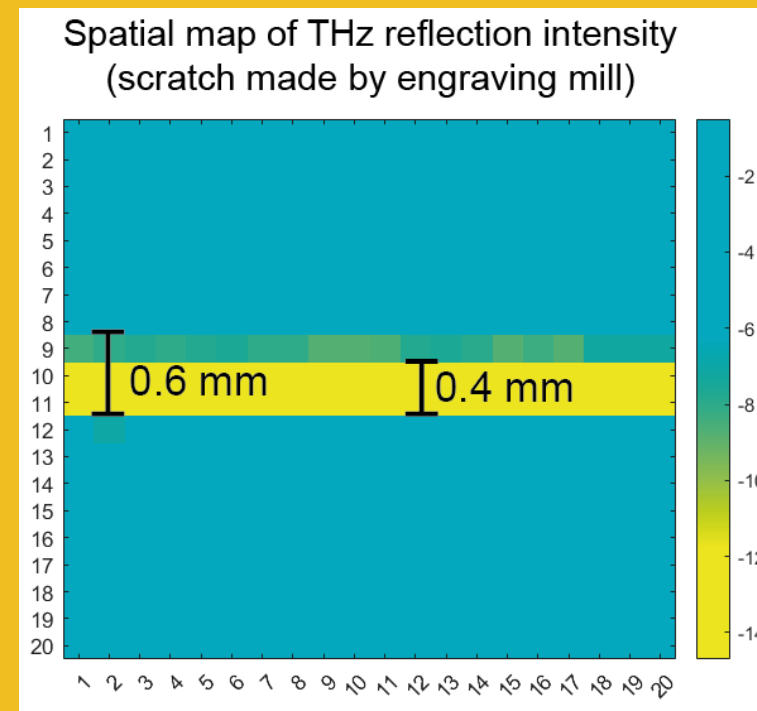

Results

Other studies have utilized THz technology for CFRP inspection; however, they employed ultra-fast laser systems and photoconductive antennas, resulting in a costly and complex measurement process.

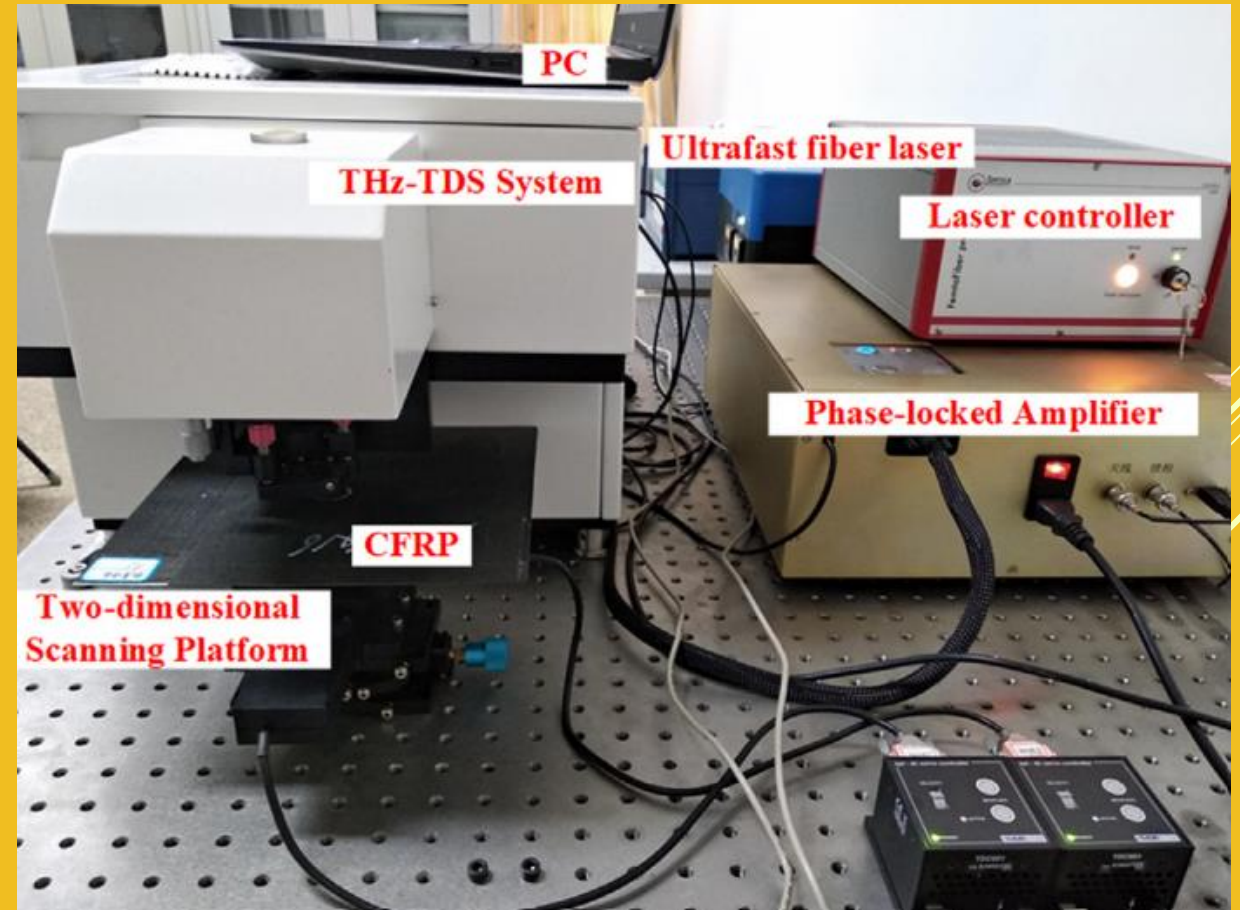

Results

In contrast, the system proposed in this work offers a cost-effective, simple, and compact solution.



Conclusions

- The proposed THz inspection system successfully detected scratches and cracks in CFRP sheets with widths ranging from 0.2 to 1.2 mm.
- In all spatial map images of THz reflection intensity, it is possible to identify scratches and cracks.

Acknowledgements

- Brazilian National Council of Scientific and Technological Development (CNPq).
- Swedish-Brazilian Research and Innovation Centre (CISB).
- Saab AB.



Thank you

euclides.chuma@ieee.org